

TIGER BOWLING SHELTER

GENERAL ASSEMBLY INSTRUCTIONS

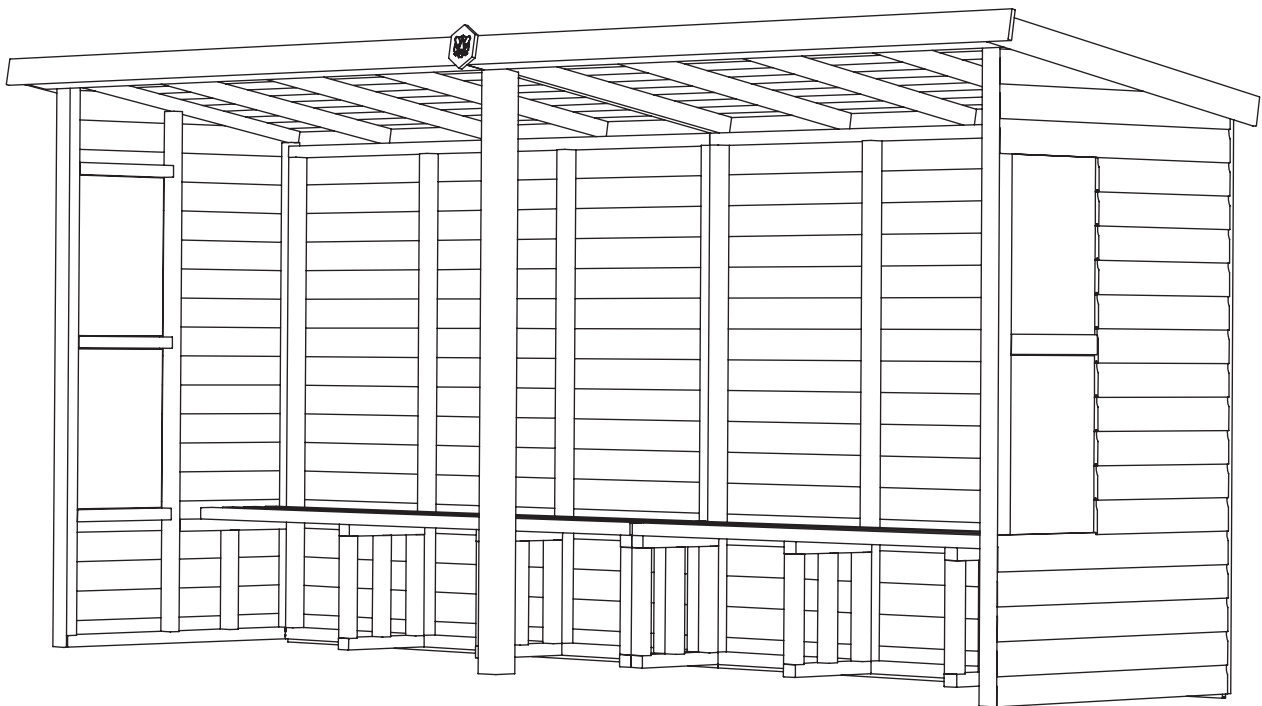

BEFORE YOU GET STARTED

PLEASE READ INSTRUCTIONS CAREFULLY

- Check the pack and make sure you have all the parts listed.
- When you are ready to start, make sure you have the right tools at hand (not supplied).
- Ensure there is plenty of space and a clean dry area for assembly.

TIMBER

As with all natural materials, timber can be affected during various weather conditions. For the duration of heavy or extended periods of rain, swelling of the wooden panels may occur. Warping of the wood may also occur during excessive dry spells due to an interior moisture loss. Unfortunately, these processes cannot be avoided but can be mitigated. It is suggested that the outdoor building is sprayed with water during extended periods of warm sunshine and sheltered as much as possible during rain or snow.

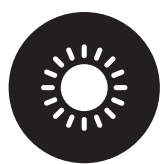

SUMMER
CONTRACTION



WINTER
EXPANSION



WOOD WARPING
MAY OCCUR

To validate your guarantee and ensure longevity of the product, it is **ESSENTIAL** that your building is treated with an appropriate high-quality oil or solvent based preservative **AFTER** assembly, both internally and externally, and annually thereafter. All glazing units must be sealed (internally and externally) with silicone or other watertight sealant.

BUILDING A BASE

Care must be taken to ensure the product is placed on a suitable base. When thinking about where the building and base is going to be constructed, ensure that there will be access to all sides for maintenance work and annual treatment.

Ensure the base is firm and level and is built on firm ground, to prevent distortion.

The constructed base must be at least the size of product as referenced in supplied construct diagram. It is also recommended that the floor be at least 25mm above the surrounding ground level to avoid flooding.

TYPES OF BASE

- Durable plastic grid*
- Concrete 75mm laid on top of 75mm hard-core.
- Slabs laid on 50mm of sharp sand.
- Timber Base - Self constructed/Buy pre-made.



PLASTIC BASE



CONCRETE BASE



SLAB BASE



TIMBER BASE



BROKEN SLABS



BARE SOIL



LOOSE GRAVEL

**We recommend a Fastfit EcoBase for your building. It is durable, lightweight, flexible and easy to put in place. Please see [tigersheds.com](https://www.tigersheds.com) for details.*

CAUTION:

All buildings should be erected by two competent adults.



CAUTION:

It is advisable to wear gloves during building installation.



The mark of responsible forestry
FSC® C125286



MADE IN THE UK SINCE 1913.

We have been making our high quality, great value garden buildings here in Britain for decades.

Pressure Treated Buildings & Treatment:

Our Pressure Treated (or tanalised) Range of buildings are impregnated with Tanalith-E - the latest generation wood preservative. This has a pale green tint to the timber as the treatment is a copper-based product designed to limit the chance of rot and insect attack. Once erected, your building should be treated annually, both internally and externally with an appropriate high-quality oil or solvent based preservative.

Whilst all products manufactured are made to the highest standards of safety, we cannot accept responsibility for your safety whilst erecting or using this product.

GO WITH THE PRO!

We understand how busy life can be. Our Pro-Installation service can take the stress and strain out of assembling your quality Tiger building for you. We recommend using professional and dedicated installers to erect your building. With their knowledge and experience, they will ensure that your cabin is put properly in place ready for you to enjoy your space for years to come.

If you have not booked our Pro-Installation service and would like to arrange an installation, please contact our friendly customer support team on **0113 205 4189** (Mon - Fri 9am-5pm) or email **sales@tigersheds.com**.

- The pro-install team will contact you to arrange a suitable time and date for the fitting.
- Sit back, relax and let our professional home installation service do all the hard work for you!
- Please view the Pro Installation page on tigersheds.com for full terms & conditions and to see if your postcode area is covered by our Pro-Install teams.

BEFORE YOU GET STARTED - PRE ASSEMBLY

TOOLS REQUIRED:

We recommend using the following tools (not supplied):



HAMMER



RUBBER MALLET



LADDER



TAPE MEASURE



SHARP KNIFE



SPIRIT LEVEL



SCREWDRIVER +



WOOD SAW



SPANNER

FIXING KIT GUIDES:

FX06 - NAIL KITS HEAVY DUTY

For Heavy Duty Shed Products:

- CN13** Clout Nails (*13mm Galvanised - QTY 450*)
- PP25** Panel Pins (*25mm - QTY 200*)
- N40** Nail (*40mm Galvanised - QTY 85*)
- NG5** Nail (*65mm Bright - QTY 20*)
- N100** Nail (*100mm Bright - QTY 100*)
- CB100** Coach Bolts (*100mm - QTY 8*)

BUILDING PACK CONTENTS:

For full details of what should be included please see the itemised packing list that is supplied with the delivery. They are also available on request in pdf form from our helpful Customer Support team – please call: **0113 205 4189** or use the “Items Delivered Query” form at **tigersheds.com/contact**.

- Assembly is straightforward if you follow these step-by-step instructions.
- We recommend getting everything aligned properly before screwing together and that **screw holes should be pre-drilled to avoid splitting the timber.** *(Do not come pre-drilled).*

IMPORTANT

- Before assembly, please make sure you have a suitable base ready to erect your building on.
- Your base **MUST** be firm and level to ensure that the building is assembled properly and is square.
- **DO NOT** start your build until you have checked that all the parts of your building are present, correct and in a suitable condition.
- Panels may have become twisted during loading/unloading and/or transportation. Please check that all framing and cladding are square before beginning assembly.
- If you are organising a third party to install your building, it is best practice not to schedule this immediately on receipt of your order, to give you time to check your delivery

TIGER BOWLING SHELTER - GENERAL ASSEMBLY INSTRUCTIONS

Step 1:

INSTALLING SIDE AND GABLE PANELS

- Position one end gable and side panel as shown. **(Detail A1)**
NOTE: CHECK THAT ALL PANELS ARE AT RIGHT ANGLES TO EACH OTHER AND THE FLOOR.
- Secure together with 5x N40 evenly spaced. **(Detail A2)**
- Repeat process for remaining gable and side panel.

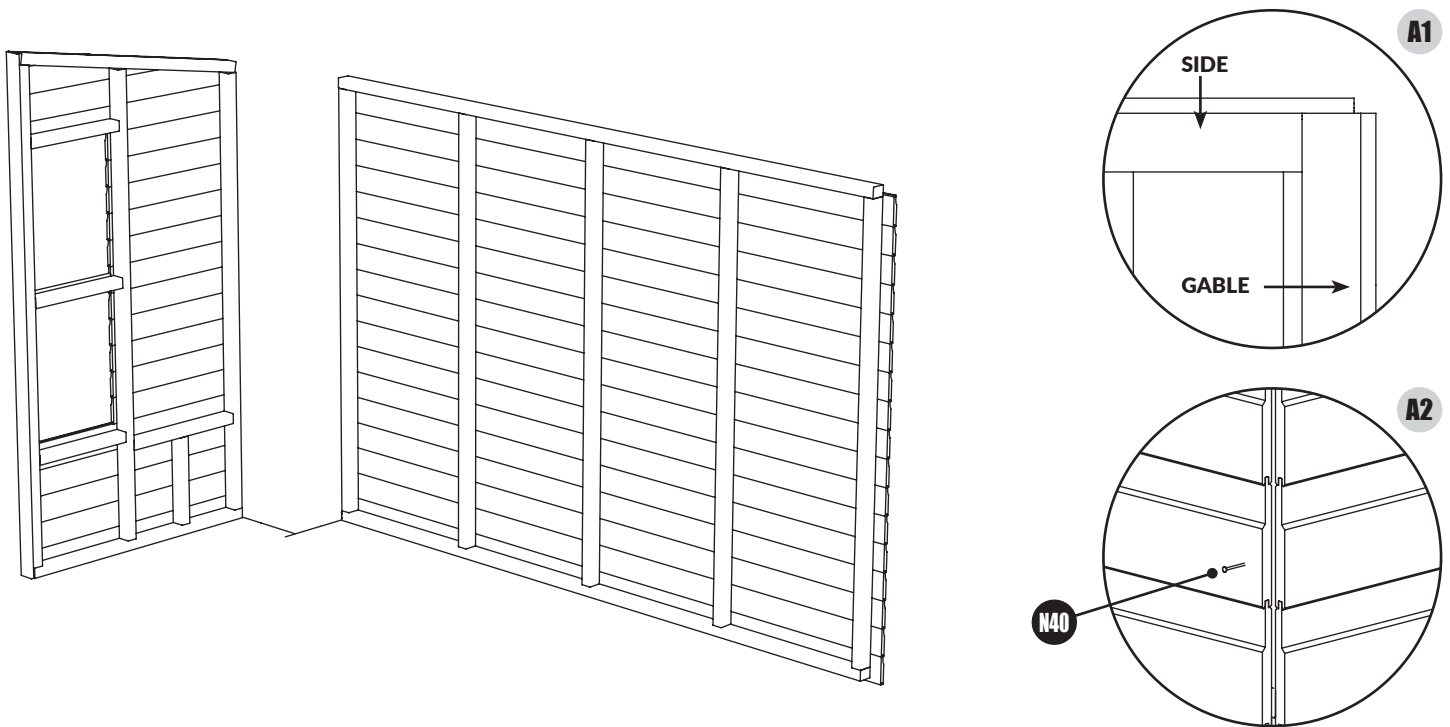

- For side panels made of 2 or more sections, secure together using 5x N100 evenly spaced through internal framework. **(Detail A3 & A4)**

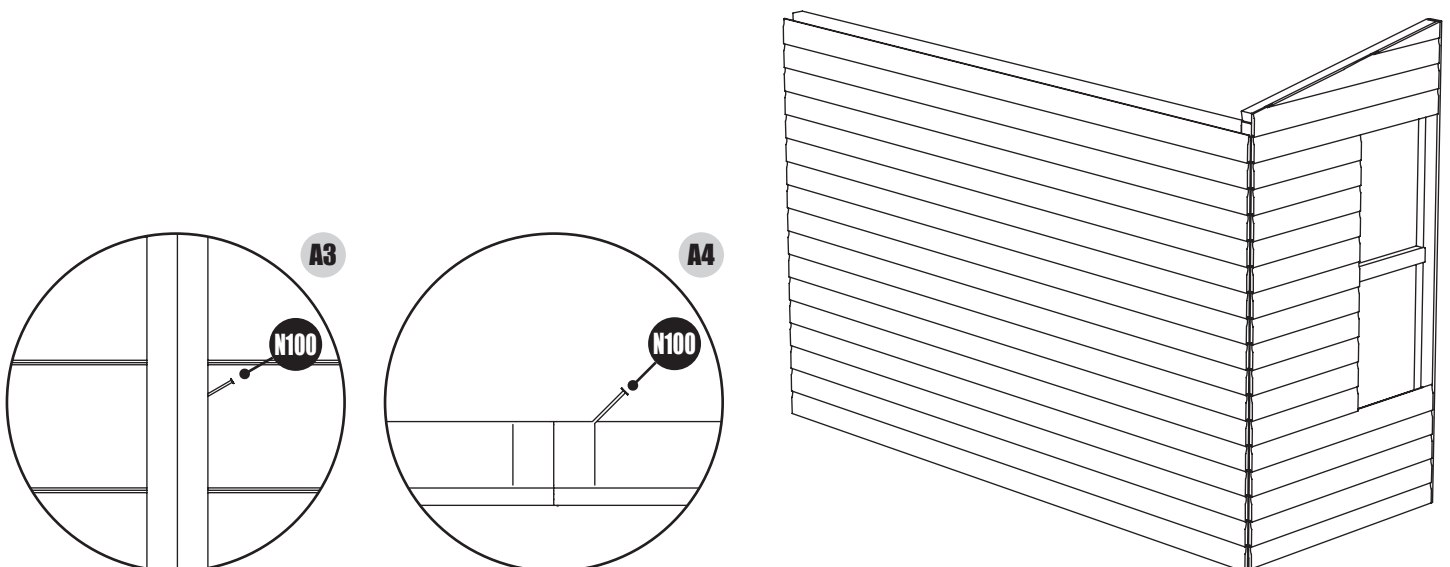

Step 3:

SECURING SIDE AND GABLE PANELS

- Locate pre-drilled holes in gable panels. **(Detail B1)**
NOTE: THESE MAY HAVE COVERED OVER DURING PANEL COATING PROCESS. THEY MAY RESEMBLE NAIL HEADS.
- Use 2x CB100 per gable, through the pre-drilled holes in each gable, from the outside. **(Detail B2)**
NOTE: DO NOT FULLY TIGHTEN.

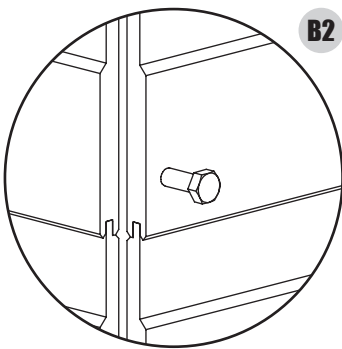
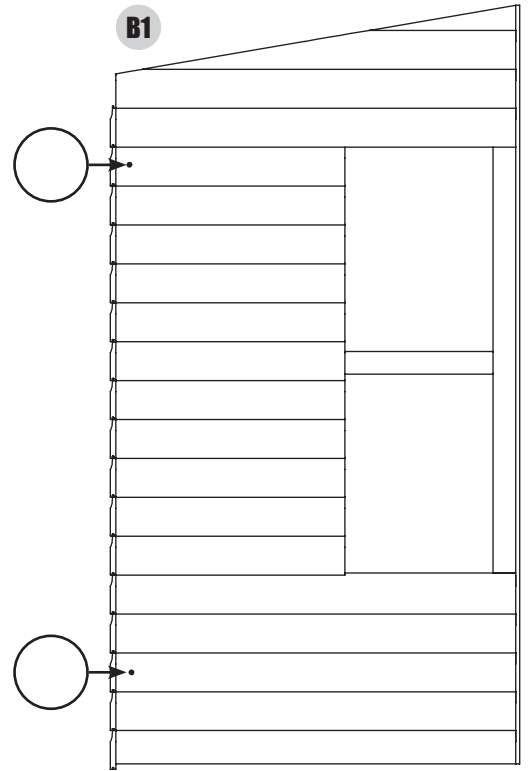

- Check panels are square by measuring between points shown. **(Detail B3)**
- If measurements are equal, your panels are square. If not, manually adjust to suit.
NOTE: DO NOT TRIM.
- Tighten 4x CB100. **(Detail B4)**
NOTE: CHECK THAT ALL PANELS ARE AT RIGHT ANGLES TO EACH OTHER AND THE BASE.

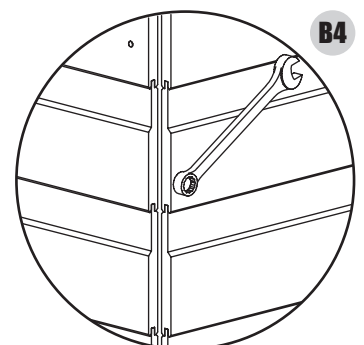
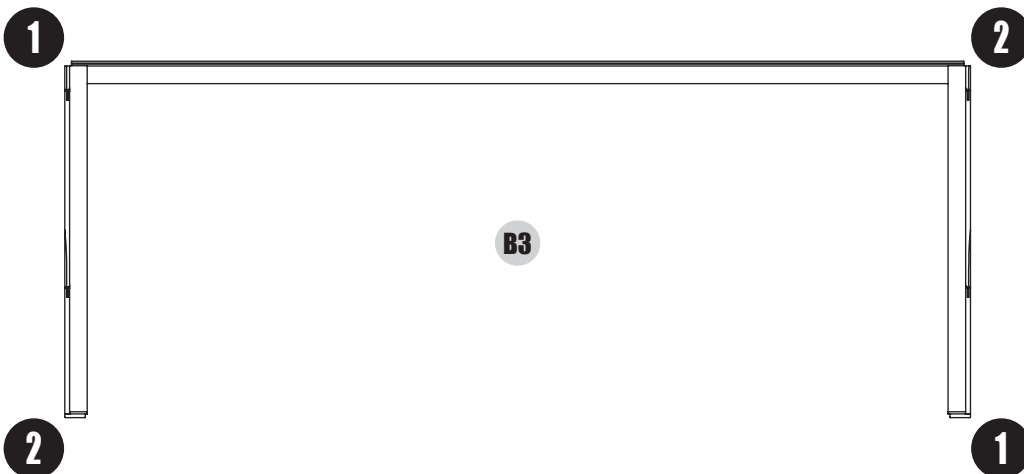

Step 3:

SINGLE PIECE ROOF INSTALLATION

- Attach roof panels as shown. Ensuring that side with pre-fitted soffit board is to the high side. **(Detail C1)**
- Fix roof to panels using N65 provided though roof boards into upright framing in panels. **(Detail C2)**
NOTE: CHECK OVERHANGS ARE EQUAL AT EACH END AND FRONT TO BACK.
- Fix low side soffit (55mm wide cut bargeboard) to the underside of the roof on the low side. This is supplied in your polytube. Fix using 3x N40 into roof framing per soffit board. **(Detail C3 & C4)**

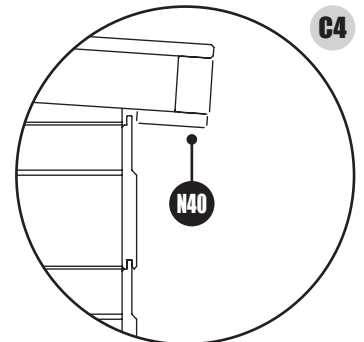
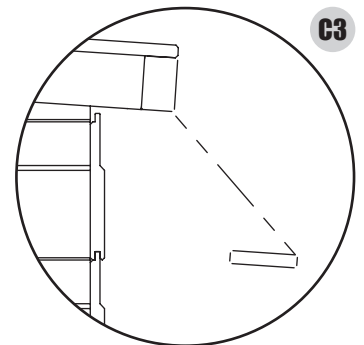
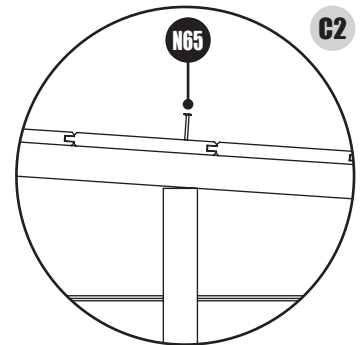
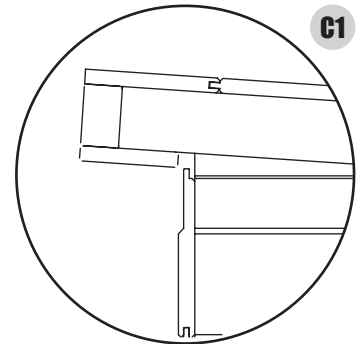
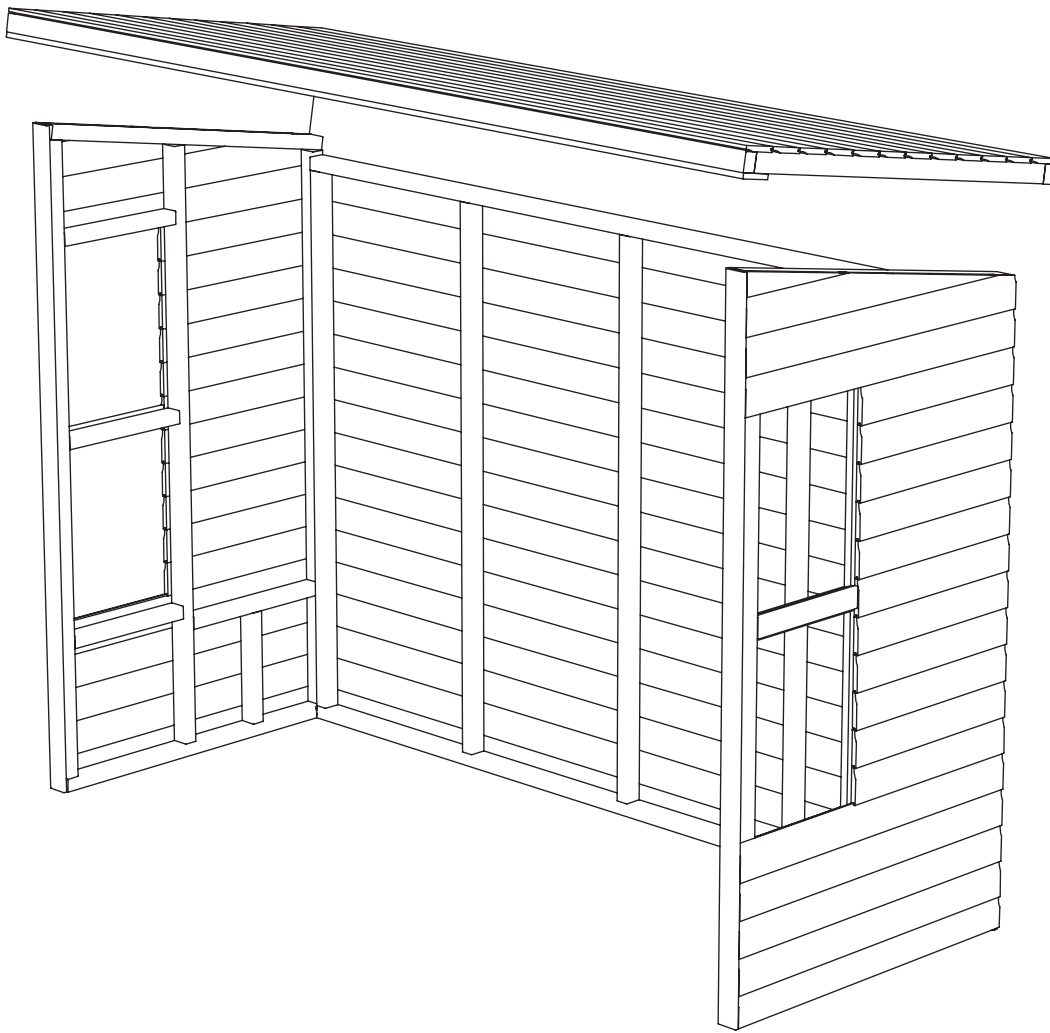

TOP TIP

If your roof does not sit correctly, it suggests the building is not sitting square. Check that the building isn't twisted by lifting two opposite corners of the building to straighten it out. This should bring the roof into alignment for you to nail into position.

Step 3b:

MULTI PIECE ROOF INSTALLATION

- For roofs that come in multiple sections. Lift into place and butt together. *(Detail C5)*
NOTE: CHECK OVERHANGS ARE EQUAL AT EACH END AND FRONT TO BACK.
- Secure together using 4x N100 per join so that roof panel is one piece. *(Detail C5 & C6)*
- Fix roof to panels using N65 provided though roof boards into upright framing in panels. *(Detail C2)*
- Fix low side soffit (55mm wide cut bargeboard) to the underside of the roof on the low side. This is supplied in your polytube. Fix using 3x N40 into roof framing per soffit board. *(Detail C3 & C4)*
NOTE: SOFFITS FOR LONGER BUILDINGS IN 2 PIECES.

C5

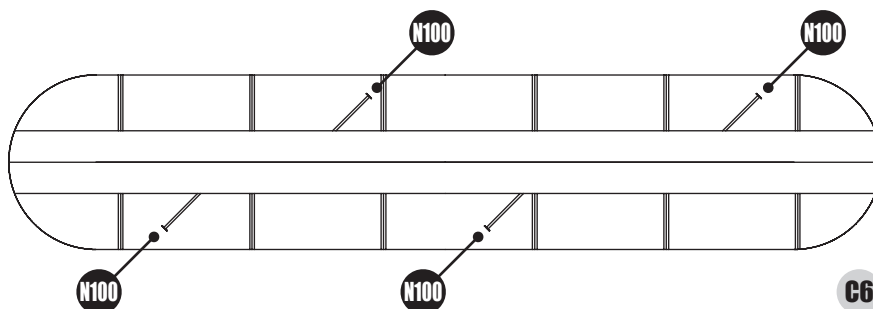
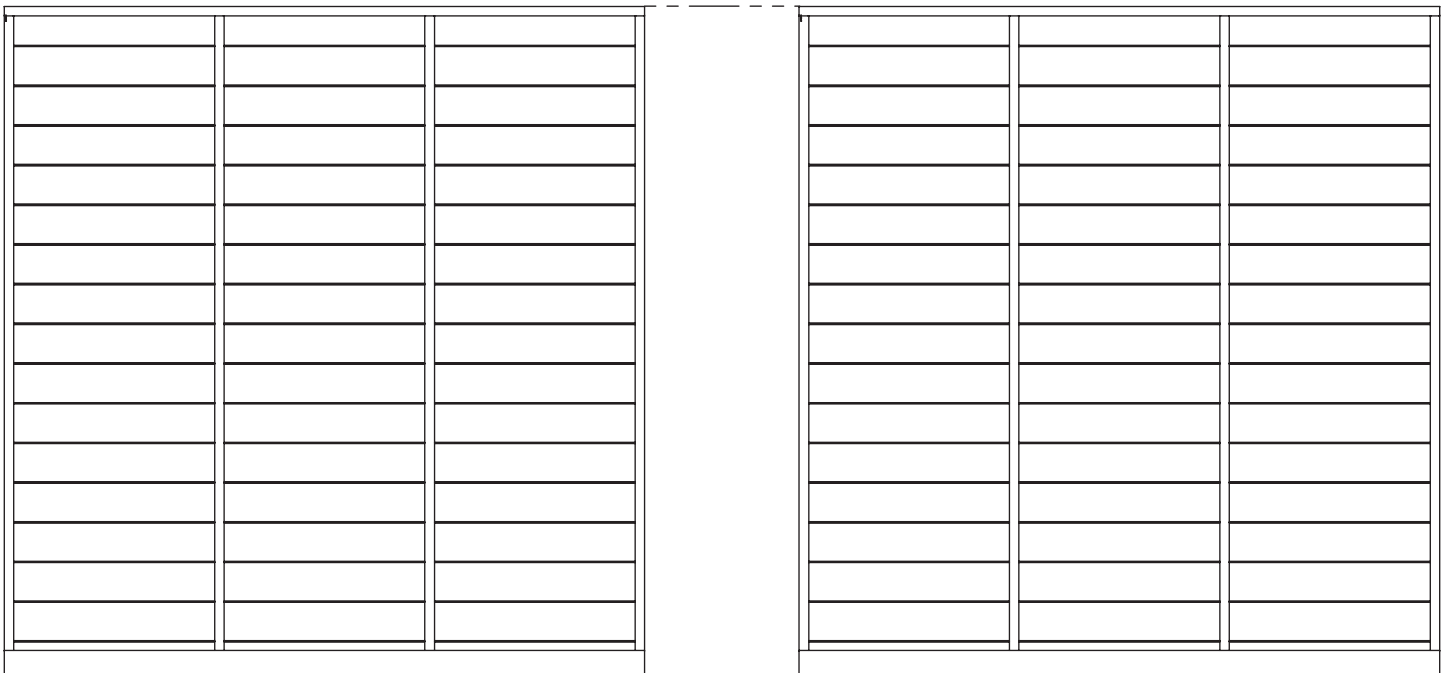

Step 4:

UPRIGHT POST

- Position upright post centrally on high side of bowling shelter.
- Secure the post to your desired base using suitable method.
NOTE: TIGER SHEDS DOES NOT PROVIDE GROUND FIXINGS AS STANDARD
- Secure through roof panel into upright post using 4x N100 nails. *(Detail D1)*

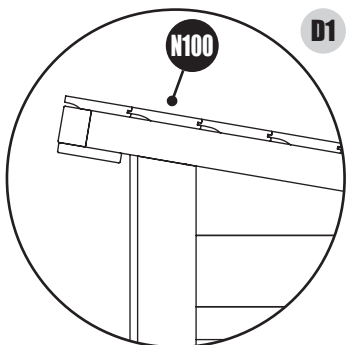
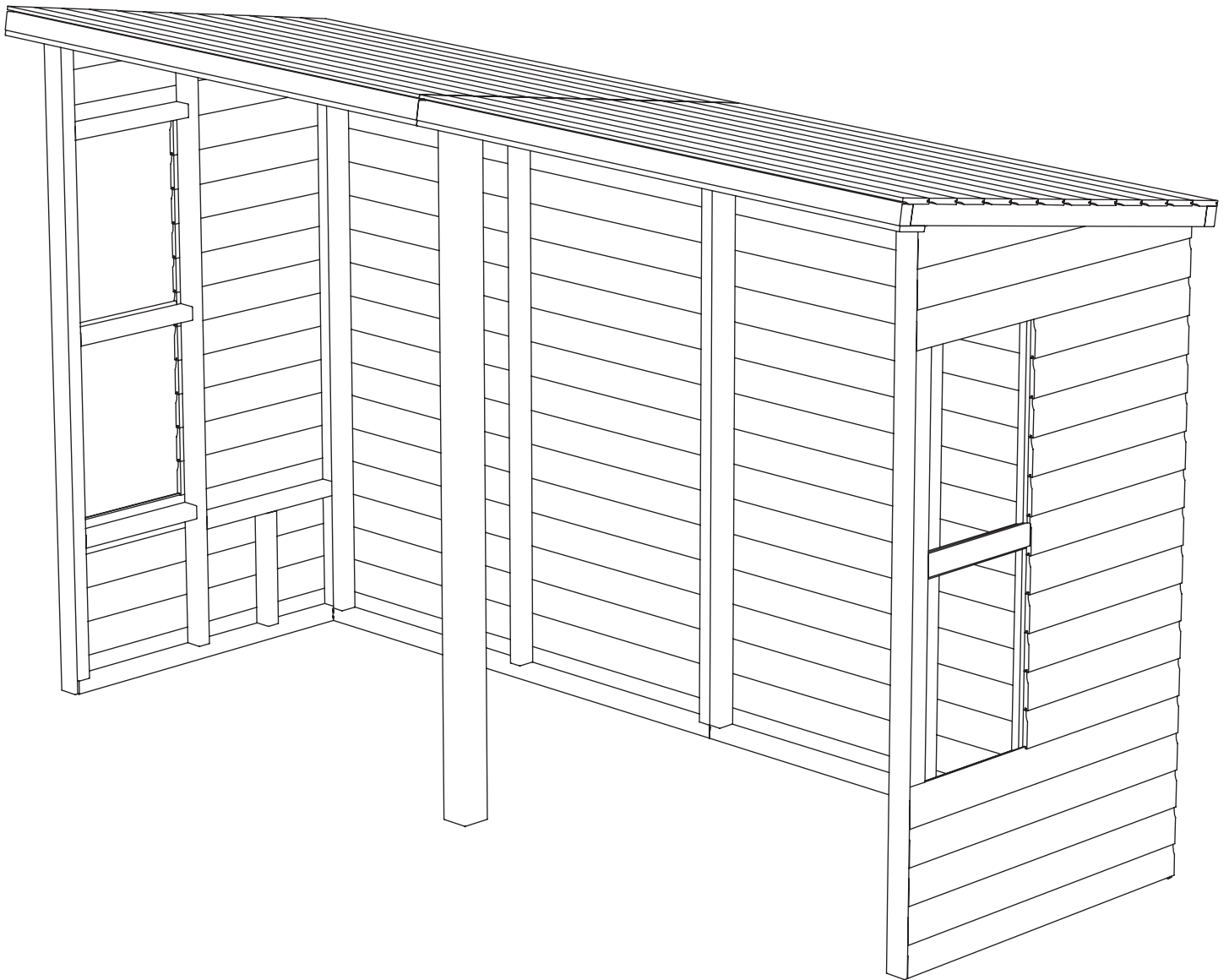

Step 5:

BENCH INSTALLATION

- Position seat leg against back wall, in line with upright framing. Secure to upright framing through seat leg using 2x N65 per leg. **(Detail E1)**
- Repeat for remaining seat legs.
- Position bench tops onto seat legs. Secure to seat legs through seat top using 1x N65 per top per leg. **(Detail E2)**

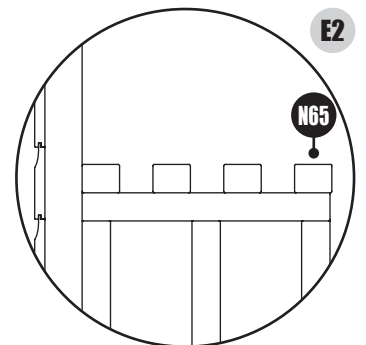
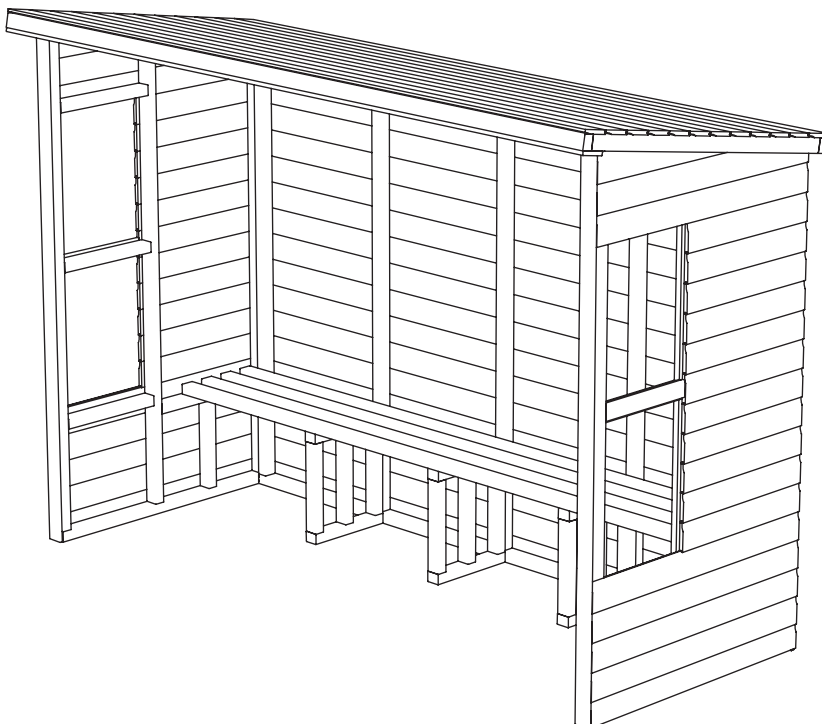
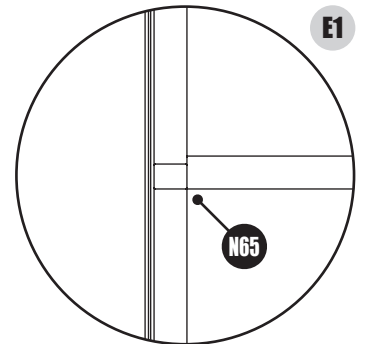
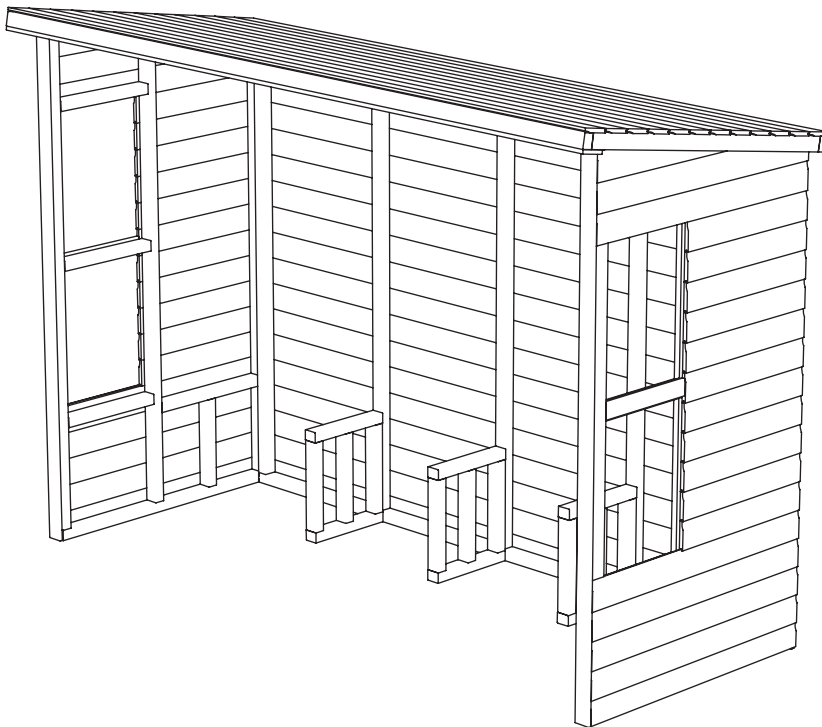

TIGER BOWLING SHELTER - GENERAL ASSEMBLY INSTRUCTIONS

Step 6:

FELTING THE ROOF - MEASURE AND CUT BEFORE FITTING

- Roll felt out onto a clean flat surface 30 minutes before you need it so it has a chance to flatten out.
- Measure length of roof and allow 35mm overhang at each end. Cut each strip of felt to size. Use a straight edge to guide cutting.
- Roll cut felt piece along low side of roof, Section 1, leaving sufficient overhang to fold down onto roof edge.
- Do not fold underneath roof. **(Detail F1 & F2)**
- Once felt is rolled out, fix felt to roof boards using CN13 at each end, making sure the felt is straight. Fix to roof skirting at approx. 100mm intervals. **(Detail F3)**
- Ensure the felt is tight, then secure the top side of felt using CN13 at approx. 100mm intervals.
- Repeat for remaining felt, working from the low side of roof to the high side, overlapping the felt by 75mm until the roof is fully covered.
- Fold the overhanging felt at ends under roof panel and tack in place.

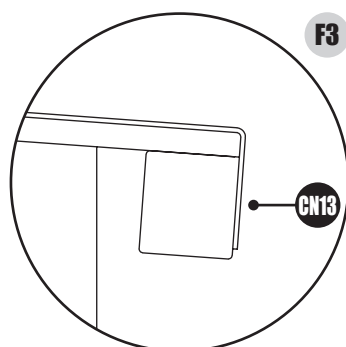
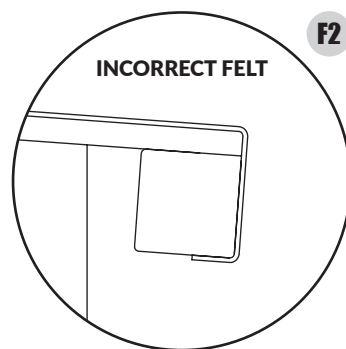
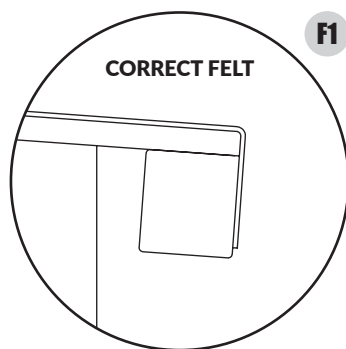
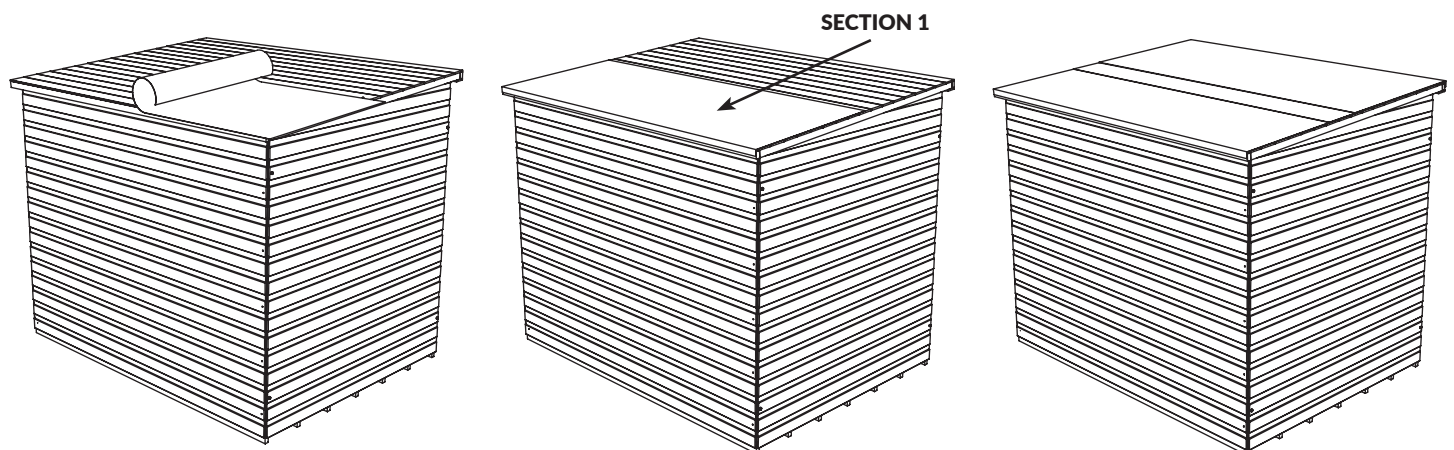

FELT REQUIREMENTS		
WIDTH OF SHED GABLE (FT)	LENGTHS OF 1m WIDE FELT	LENGTHS OF 0.5m WIDE FELT
3	1	1
4	2	
5	2	
6	2	1
7	3	
8	3	1
9	4	
10	4	

Each length of felt used is enough to cover the length of the roof plus overhang. Example: 8x4 Bowling Shelter will be supplied with roll of felt to cover 16ft plus overhangs at each end. This is to be cut into two lengths, see table above, by the customer to provide the correct coverage. (see table above)

Step 7:

FITTING FASCIA BOARDS (BARGEBOARDS) & FINIAL

- Fit bargeboards to the roof, trapping overhanging end of the felt in between the roof and bargeboard.
- Secure using 5x N40 per front bargeboard through roof panel.
- Secure using 2x N40 per gable bargeboard through roof panel.

NOTE: THERE ARE NO BARGEBOARDS SUPPLIED FOR LOW SIDE OF ROOF AS THIS WILL PREVENT EFFECTIVE WATER DRAINAGE.

- Secure finial over the top of the bargeboards using 2x N40 per finial. (Optional)

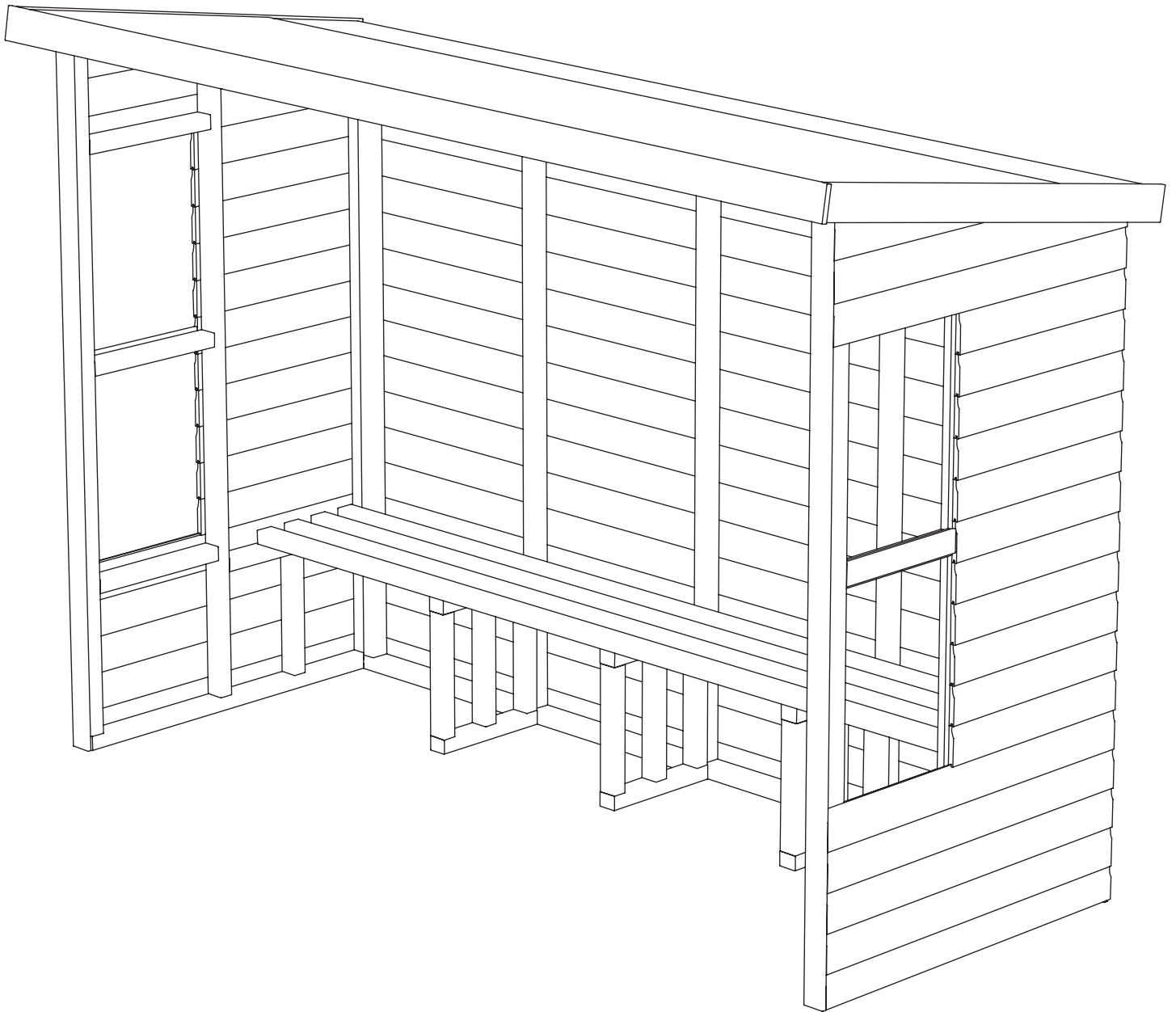

Step 8:

FIT CORNER STRIPS AND COVER STRIPS - CERTAIN SIZES ONLY

- Secure the corner strips at each corner of the shed with 4x N40 per corner strip.

NOTE: THESE CORNER STRIPS MAY NEED CUTTING TO SIZE.

NOTE: NOT TO BE CONFUSED WITH WINDOW BEADING.

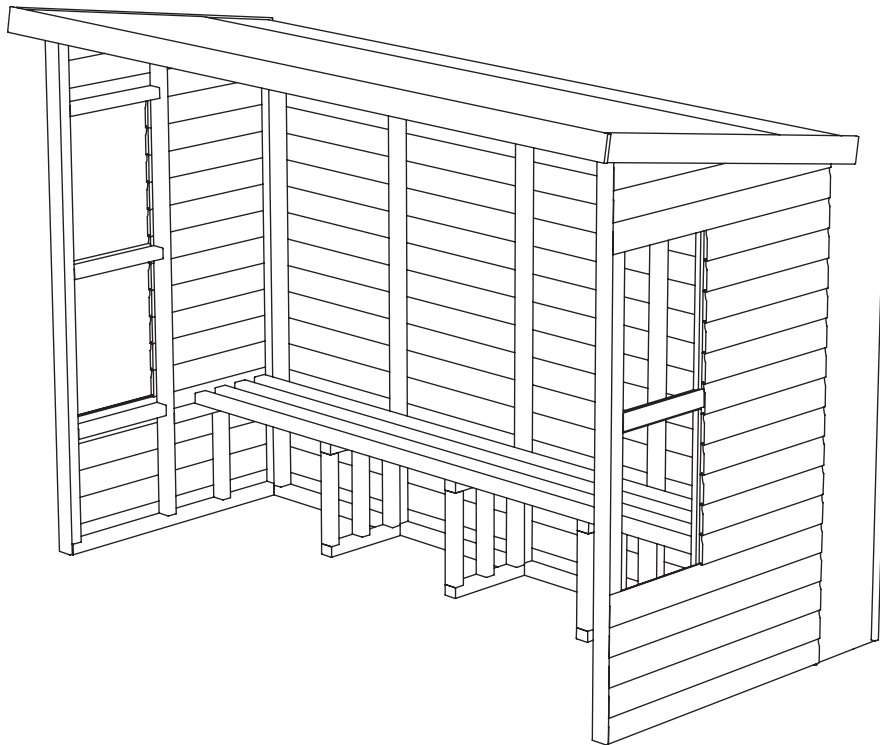

- On sheds with a join in the side panels, use cover strip to hide join. Secure to sides using 4x N40 per cover strip. *(Detail G)*

NOTE: THESE COVER STRIPS MAY NEED CUTTING TO SIZE.

NOTE: NOT TO BE CONFUSED WITH BARGEBOARD.

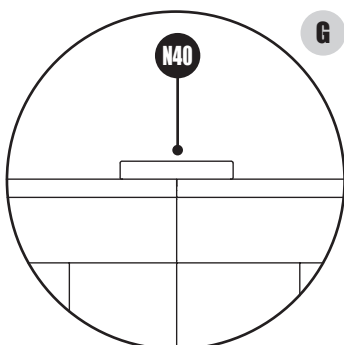
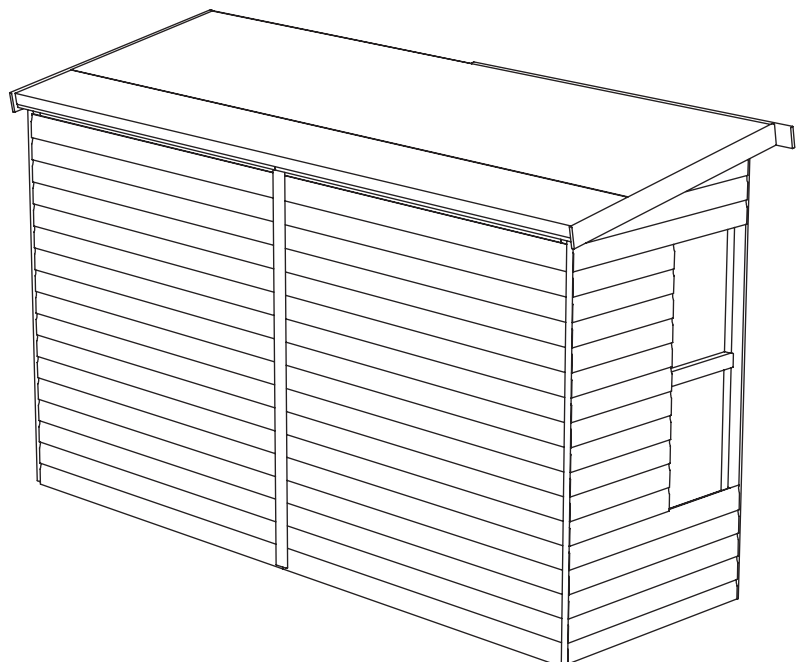

Step 9:

INSTALLING GLAZING

- Glaze windows by securing glass/styrene with PP25 supplied, from the inside. *(Detail H)*

NOTE: ALL WINDOWS MUST BE SEALED INSIDE AND OUT WITH SILICONE, PUTTY, OR ANY OTHER WATER-TIGHT SOLUTION. (NOT SUPPLIED).

NOTE: PLEASE DO NOT CONFUSE YOUR CORNER STRIPS WITH WINDOW BEADING.

WE DO NOT SUPPLY WINDOW BEADING AS STANDARD WITH OUR BUILDINGS UNLESS ORDERED.

- Contact our friendly customer support team to order a standard window glazing kit, complete with beading and sealant.

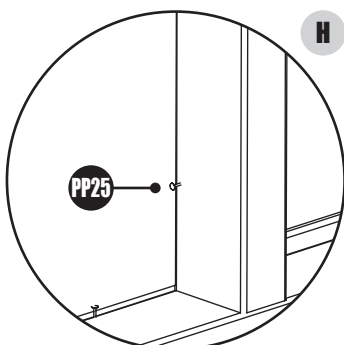
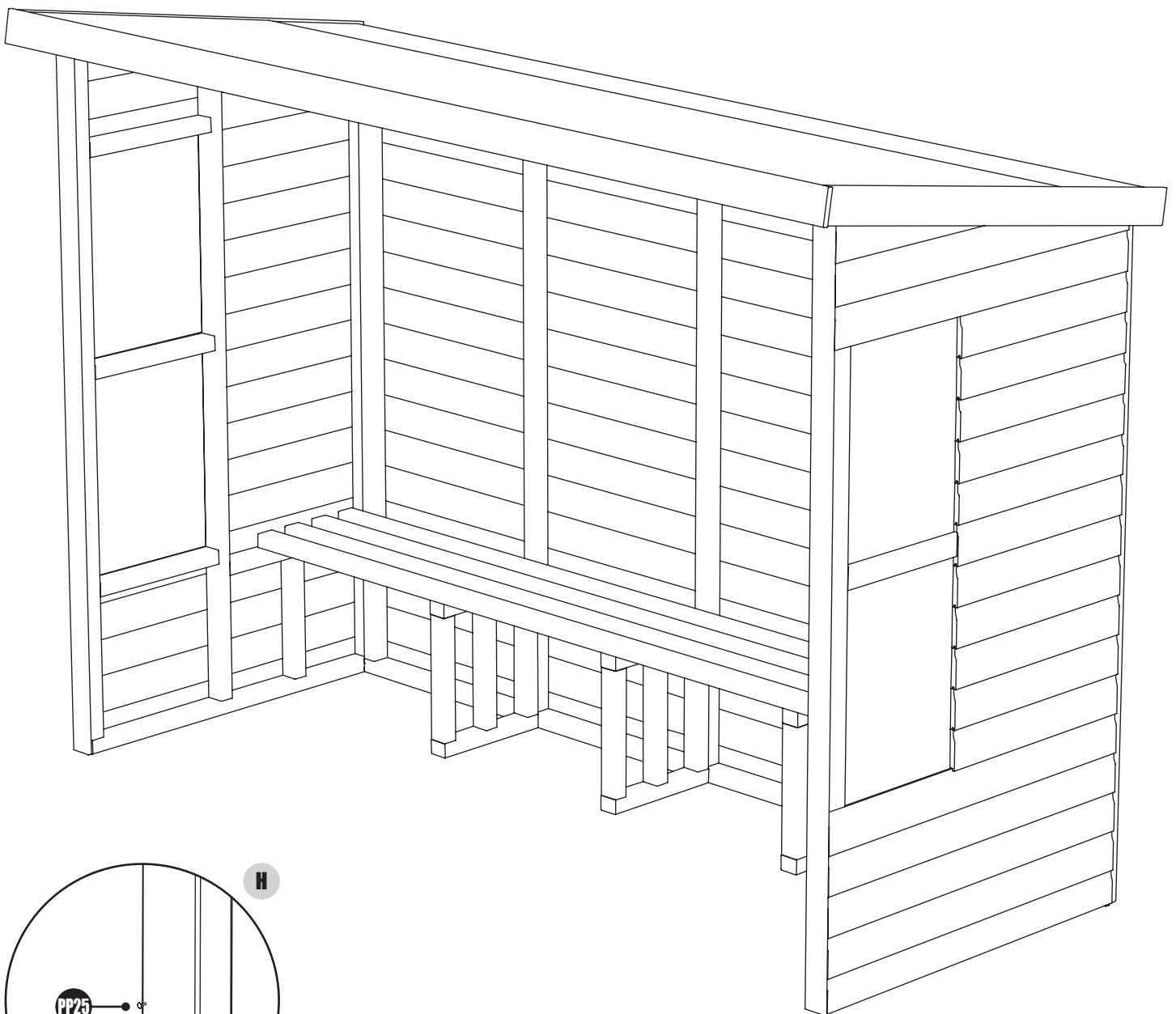



Head Office

Calverley Lane,
Rodley,
Leeds,
West Yorkshire,
LS13 1NP

Telephone: 0113 205 4189
Website: tigersheds.com
Email: customersupport@tigersheds.com



SCAN CODE!
TO SEE GENERAL ACCESSORY &
INSTALLATION VIDEO LIBRARY

